



RAPTOR 300

COMPACT AND FLEXIBLE



Pinotti[®]



STAY FLEXIBLE...

The RAPTOR 300 is the chameleon of the mulching carriers that provides unparalleled customization possibilities to answer the individual requirements of each end user. The modular design, in combination with various options, allow multiple configurations. Accessibility and the compact architecture make this unit stand out when speaking of ergonomcy & efficiency. Featuring the latest technology and heavy-duty components, the RAPTOR 300 sets new standards in the mulching industry.

Pinotti

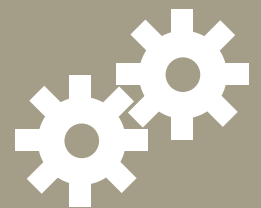

EFFICIENCY

The mechanical drive generates important fuel savings and improves efficiency compared to hydraulically-driven mulchers.



RELIABILITY

As with all of PRINOTH's products, reliability and durability are the top priorities.



VERSATILITY

Mobility, transportability and attachments possibilities add up to qualify the RAPTOR 300 as one of the most versatile units on the market.



SAFETY

We emphasize on safety features for operator and vehicle. All models from the RAPTOR series line-up benefit from the same highly-certified safety systems.



UNDERCARRIAGE – DELTA TRACKS »

- » improved robustness
- » better self-cleaning effect
- » better off-road mobility

The shape of the undercarriage protects the vehicle in case of barriers like stumps and rocks and simplifies backwards operations.



PTO DRIVE »

- » adaptive to all attachments
- » direct drive efficiency
- » robust and reliable

The RAPTOR 300 becomes a multi-purpose machine as attachments can be easily switched according to the type of work to be done.



POWERBELT DRIVE »

- » robust and reliable
- » direct-drive efficiency
- » increased range of lifting

The durable and low-maintenance PowerBelt drive has a lifting height limit that is unique to a mechanically-driven head.



ACCESSIBILITY »

- » tilting cab
- » service friendly architecture
- » five full-access doors

All components that require maintenance or monitoring are located near the service doors and can be easily reached.

TECHNICAL HIGHLIGHTS

Pinotti







... BE SAFE

CAB »

- » Customized
- » Ergonomic
- » Comfortable

Best in class cab for safe and productive operation.



Pinotti

TIER 4 FINAL/STAGE 4

Engine	CAT C7.1
Power	275 HP
Displacement	7 l
Max. torque	1257 Nm
Tank	360 l (95 gal)
Urea tank (AdBlue)	26 l (6.8 gal)

Voltage	24 V
Hydraulic tank	62 l

TIER 3/STAGE 3A

Engine	CAT C7.1
Power	275 HP
Displacement	7 l
Max. torque	1030 Nm
Tank	360 l (95 gal)

Voltage	24 V
Hydraulic tank	62 l

ATTACHMENTS

PTO:	
M550 m	2200 kg (4850 lb)
M650 m	2850 kg (6280 lb)
RF800 m	3500 kg (7716 lb)
All other 3-point-hitch attachments	
PowerBelt:	
M650 m	2750 kg (6060 lb)

UNDERCARRIAGE

Max. speed	7.5 km/h (4.6 mph)
Undercarriage type	D4
Grouser shoes	one blade/dual blade

Grouser	Width	Gauge
(mm/in)	(mm/in)	(mm/in)
600/23.5	2200/86.5	(1600/63)
730/28.7	2500/98.5	(1750/69)

WEIGHT AND MOBILITY

Weight:	
with M650 m	15250 kg (33620 lb)
without attachment	12400 kg (27337 lb)

Ground pressure:	
600 mm grouser	340 g/cm ² (4.8 PSI)
730 mm grouser	280 g/cm ² (4.0 PSI)

Climbing ability sideways	30°
Climbing ability frontal	45°

OPTIONS

- Winch
- Pressurized cab
- Fire suppression system
- Arctic package
- GPS
- Hitch
- Additional roll bar protection
- Coolant heating system
- Locking system for tracks
- Central lubrication system
- Additional hydraulic circuit
- etc.

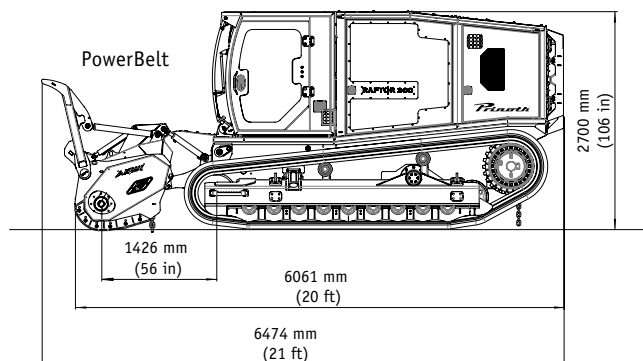
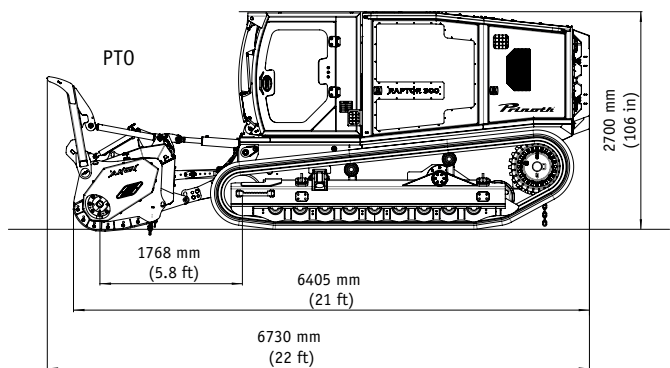
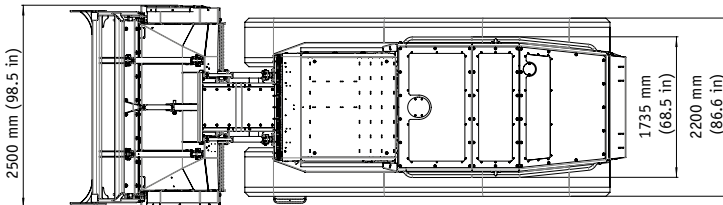

TECHNICAL DATA





Other sales and service sites can be found on www.prinoth.com

AHWI Maschinenbau GmbH
Im Branden 15
D-88634 Herdwangen
Phone: +49 (0)7557 9212-0
Fax: +49 (0)7557 9212-92
ahwi@prinoth.com

PRINOTH AG
Brennerstraße 34
I-39049 Sterzing (BZ)
Phone: +39 0472 72 26 22
Fax: +39 0472 72 26 18
prinoth@prinoth.com

PRINOTH Ltd. (Canada)
North American Headquarters
1001, J.-A.-Bombardier Street
Granby (Quebec) J2J 1E9,
Phone: +1.450.776.3600
Fax: +1.450.776.3685
prinoth.canada@prinoth.com